

Roll No.

Total No. of Pages : 02

Total No. of Questions : 08

M.Tech (ME) (Sem-2,3)

MAINTENANCE AND RELIABILITY ENGINEERING

Subject Code : MTME-211

M.Code : 74987

Date of Examination : 16-06-2023

Time : 3 Hrs.

Max. Marks : 100

INSTRUCTIONS TO CANDIDATES :

1. Attempt any FIVE questions out of EIGHT questions.
2. Each question carries TWENTY marks.

1. a) How is maintenance important? Write the objectives of Maintenance.
b) What do you mean by Preventive maintenance? Classify and explain the factors affecting its efficiency.
2. a) Explain the short term and long term maintenance planning.
b) Show the closed box pattern of engineering maintenance using block diagram.
3. a) Classify the Hazards and discuss the procedure to minimize the hazards
b) Explain the housekeeping maintenance and inspection in details.
4. a) What are various types of safety devices used in automobile industries? Explain their specific applications.
b) Derive the expressions for Mean time between failure and mean time to repair.
5. Derive the expressions for Reliability, MTBF and hazard rate for series, parallel and stand by configurations.
6. **Write the short notes on the following :**
Total Productive Maintenance
5-WHY concept for root causes
Application and derivation of Kuder-Richardson formula.

7. Describe the fault tree and success tree method and block diagram method for system reliability analysis.
8. a) What are the components responsible to improve the reliability of the systems?
- b) Find the system reliability of the following series-parallel configuration in Fig. 1, for which components reliabilities are given.

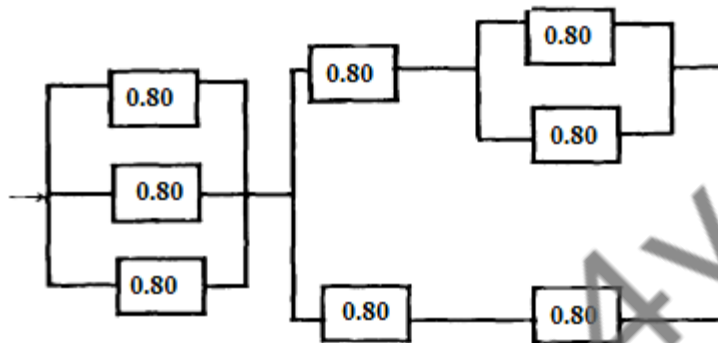

NOTE : Disclosure of Identity by writing Mobile No. or Making of passing request on any page of Answer Sheet will lead to UMC against the Student.